



Durable Lightweight Furniture Systems

# VersiFlex & VersiFold™

## SPECIFICATIONS

Type	Panel Thickness	Panel Width	Height	Length	Weight
VersiFlex	2.25"	6.25"	78"	8'	57lbs
VersiFlex	2.25"	6.25"	78"	12'	85lbs
VersiFold™	2.25"	24"	78"	8'	36lbs

**CORE:** VERSIFLEX and VERSIFOLD™ are made of LDPE (low density polyethylene) Foam core. LDPE is a durable, lightweight, flexible, solid extruded plank. Offers excellent strength, resistance to creep under load, vibration and shock absorbency and water resistance.

In addition to being shock absorbent, it's also resistant to vibration and compression, impervious to most chemicals, non-abrasive and can withstand exposure to extreme UV radiation and ozone. Polyethylene foam is able to maintain all of these properties regardless of the temperature, making it very consistent and predictable.

**FABRIC:** VERSIFLEX and VERSIFOLD™ are covered with a uniquely engineered fabric. This fabric is made of colored fibers needle bonded into a continuous structure, then finished with a heat set, latex back to ensure fiber lock. All are soft, flexible, and acoustically absorbent fabrics suitable for high-traffic area.

And thanks to their "self-healing" nature they are ideal for tackable walls. Their excellent pill/fuzz resistance makes them Velcro compatible. This material is 100% recyclable.

**NOISE REDUCTION:** Both VERSIFLEX and VERSIFOLD™ have been independently tested by Western Electro-Acoustic Laboratory for noise reduction and were rated at .80 and .31, respectively (Noise Reduction Coefficient).

**FLAMMABILITY:** Panels & Fabric

- ASTM E-84 Tunnel Test (Class A)
- Flame Spread 15
- Smoke Density 30

(Caution: polyethylene foam is combustible and should not be exposed to flame or other ignition sources).

**UNIT TO UNIT ATTACHMENT MAGNETS:** Each unit has 8 rare-earth magnets, four on each end of opposite polarity. Rare-earth magnets are made from alloys of rare-earth elements. They are nickel-coated to protect them from breaking and chipping, hence their typically shiny, corrosion-resistant nature.

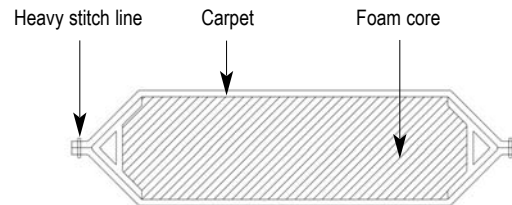

VersiFlex Cross Section

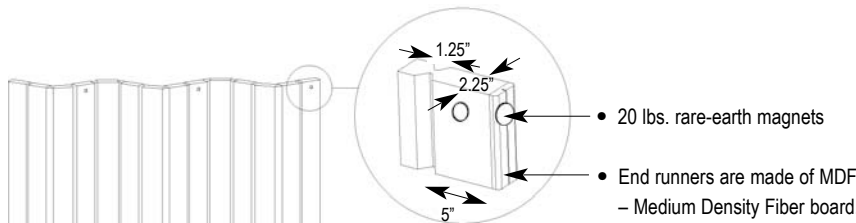

VersiFlex

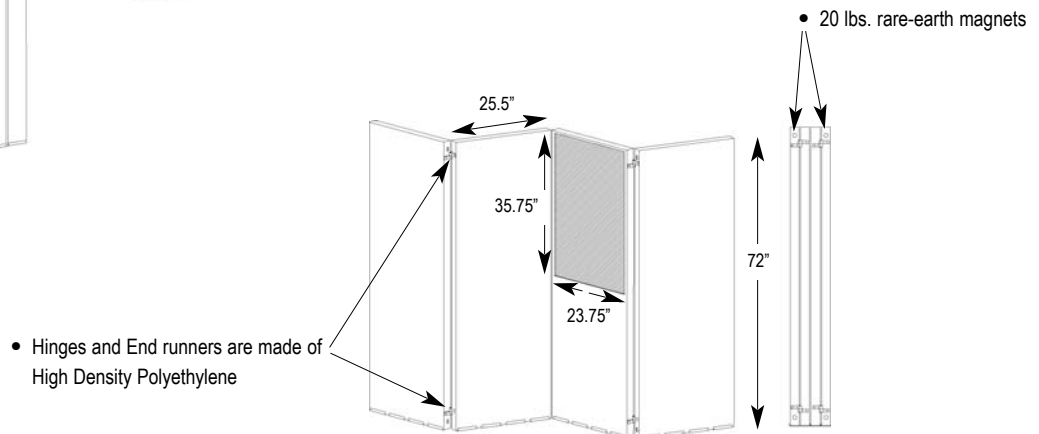

VersiFold™