

SPECIFICATIONS

Applications:

The SwiftSet® Stacking Chair Cart – 2 Wheel is available in two sizes for 15* short or 15 tall upholstered or non-upholstered SwiftSet® Stacking Chairs, but height of stack depends on angle of tilt when cart is leaned back.

Primary Structure:

Part	Material Size
Main Frame	1" x 14 gauge (.083 wall) round tubing
Handle	1 1/4 x 16 gauge (.065 wall) round tubing
Axle	3/4" cold-rolled solid steel bar
Seat Stop	1/2" x 16 gauge square tube

QUICK SPECS			
Width 22"	Height 54"	Length 29"	Weight 25 lbs.
DIMENSIONS LOADED			
Width 22"	Height 69"	Length 33"	Weight 192 lbs.

Safe Hand Truck Capacities:

*Since hand trucks rely on the strength of the operator to balance the load, there is no single "safe capacity". Conditions such as the size and strength of the operator, the weight of the furniture being moved, and the presence or absence of thresholds, ramps or slick surfaces can all affect the capacity of hand trucks. It's always better to make a few extra trips than to risk injury to yourself or others by overloading the hand truck style SwiftSet® Stacking Chair Cart.

Wheel:

Wheels are 8" diameter x 2" wide, non-marring, round tread with 3/4" ball bearings. They shall have a load capacity of not less than 500 pounds each.

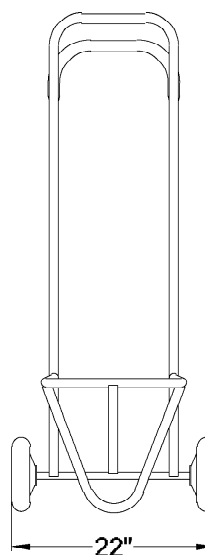
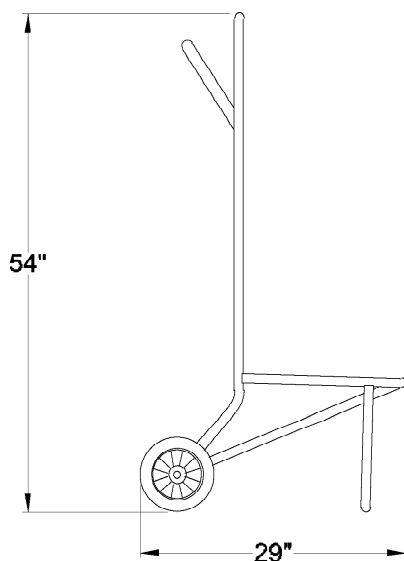

PART NUMBERS: CRTCSSKBLK2 (TALL) CRTCSSKSHBLK2 (SHORT)

www.mitylite.com 1.800.327.1692 • 1.801.224.0589 • fax 1.801.224.6191