

CT Cart – Large X



the leader in lightweight durability

SPECIFICATIONS

Applications:

The CT Cart – Large X shall hold up to 8 tables. The CT Cart – Large X shall hold all Xpediter™ tables that have a 42-48 table top.

Primary Structure:

The cart shall consist of a base, 2 swivel casters, 2 rigid casters, 3 handle sets and holding strap. This cart shall have an opening on one side, which allows the user to access the tables, making loading and unloading easier. The handle sets shall be attached to the base by inserting them into 1 1/4" x 4" sockets and shall be held in place by a 3/8"-16 x 3/4" bolt. The two side handle sets shall be connected to the back handle set by two (2) 1/4" x 1 1/2" hex-head bolts and nylock nuts. The holding strap shall be constructed of 1 1/2" nylon strap webbing, which contains a quick release buckle in the center. Base and handle specifications are as follows:

QUICK SPECS			
Width 30 1/2"	Height 43 1/2"	Length 55 1/2"	Weight 69 lbs.
Table Width		Height Loaded	
CT 42 (29")		55 1/4"	
CT 48 (29")		59 1/4"	

Part	Material Size
Base Frame	2" x 3" x 3/16" angle iron
Base U-shaped Connector	1 1/2" x 1 1/2" x 1/8" angle iron
Side handle sets	1" x 12 gauge (.109 wall) tubing
Back handle set upright	1" x 12 gauge tubing
Back Handle Cross Bar	1 1/4" x 16 gauge (.065 wall) tubing

Casters:

The cart shall have two swivel casters and two rigid casters. Wheels shall be 2" wide x 6" diameter, polyolefin, with 3/4" greasable roller bearings. Casters shall have a dynamic load capacity of not less than 850 pounds each.

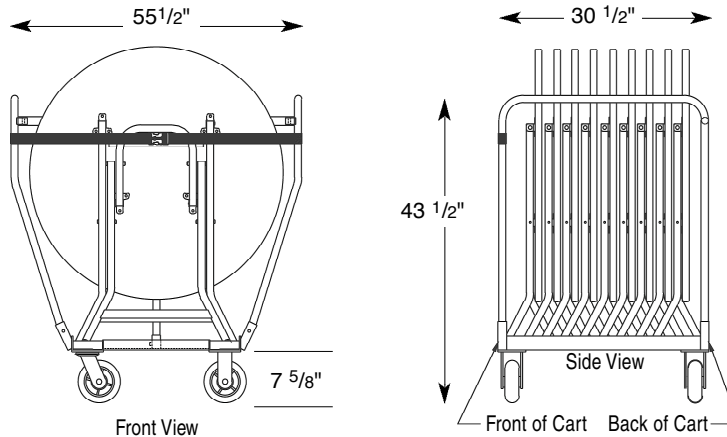

PART NUMBER EXAMPLE: CRT42-48LXBLK2

www.mitylite.com 1.800.327.1692 • 1.801.224.0589 • fax 1.801.224.6191